

Ref.: 536011



PNEUMATIC PISTON OIL PUMP, PUMPMaster 45, PM45 - 10:1, 205 L (55 GAL) DRUMS, NPT

PM45 series air operated piston pumps. Double acting air operated moderate pressure pump for very large oil systems or when a low air pressure or cold temperatures would limit pump performance. Built in port for optional pressure relief valve (PN 609 007). Flange mounted pumps. Pump 536 010 can also use bung adaptor (PN 360 006) for bung mounting. Maximum air consumption with 5 bar (72 psi) air inlet pressure and 80 cpm. Maximum noise level measured at 1 m (3.3') from the pump, 7 bar (102 psi) air pressure and free delivery. Instruction book: 853801.

Technical data

Documentation

More information

Fluids	Oil
Compatible fluids	Oil, Transmission fluid
Pump mounting	205 l (55 gal) drum bung mounted
Pressure ratio	10:1
Air pressure operating range	1,5-12 bar (21,75-174 psi)
Air consumption	850 NL/min (30 scfm)
Maximum outlet pressure	120 bar (1740 psi)
Air motor effective diameter	115 mm (4,5")
Air motor stroke	100 mm (4")
Delivery per cycle	15 l (4 gal)
Cycles per minute (aprox.)	80 cycles
Delivery	15 l/min (4 gal/min)
Maximum free flow delivery	65 l/min (17,2 gal/min)
Air inlet	1/2" NPT (F)
Fluid inlet	1 1/2" NPT (F)
Fluid inlet type	Ball check
Fluid outlet	3/4" NPT (F)
Wetted materials	Cast iron, Hard chromed steel, Steel, Polyurethane, NBR
Pump tube material	Carbon steel
Sound level	80 dB
Tube height	855 mm (33,7")
Total height	1357 mm (53,4")
Weight	17 kg (37,5 lb)

[Login](#) or [register](#) to consult this content

mm (in)	536 010
A	1.357 (54")
B	502 (20")
C	54 (2")
D	855 (34")

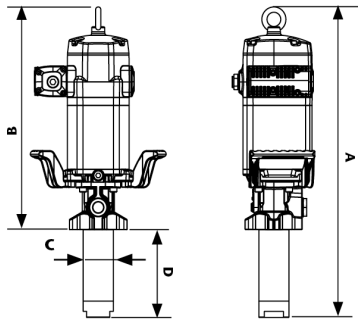

SAE 10, 21 °C (70 °F) CAPACITY CURVE

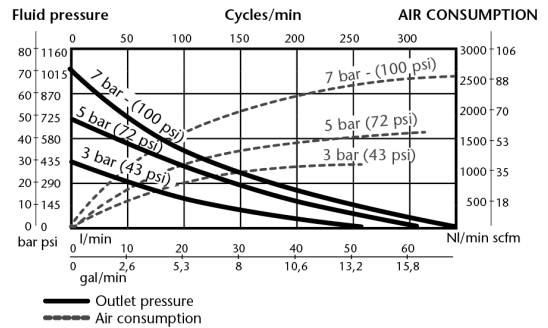

Models

Code	Fluids	Pump Mounting	Fluid Outlet	Tube Height	Total Height
536011	Oil	205 l (55 gal) drum bung mounted	3/4" NPT (F)	855 mm (33,7")	1357 mm (53,4")
536031	Oil	Universal stub pump	3/4" NPT (F)	200 mm (7,9")	702 mm (27,6")
536030	Oil	Universal stub pump	3/4" BSP (F)	200 mm (7,9")	702 mm (27,6")
536010	Oil	205 l (55 gal) drum bung mounted	3/4" BSP (F)	855 mm (33,7")	1357 mm (53,4")